

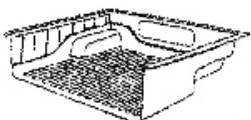

Tartozékok:

<p>A. 1db platóbélés</p> 	<p>B. 1db hátfal</p> 	<p>C. 10db 4,7x18mm</p> 	<p>D. 10 db alátét</p> 	<p>E. 10 db kupak</p> 	<p>F. 4db kétoldalú ragasztó</p> 
--	--	---	--	---	--

Szerelési útmutató:

<p>1. Vágja ki a fülkevédő rács helyét.</p> 	<p>2. Tegye a platóbélést a platóra.</p> 
<p>3. Készítse el a platón a furatokat a képen látható módon (3,5mm)</p> 	<p>4. Vegye ki a platóbélést. Készítse el a platóbélésen a furatokat a képen látható módon (5,5mm).</p> 
<p>5. Tisztítsa meg a platót.</p> 	<p>6. Fújja be korrózió gátló spray-vel.</p> 

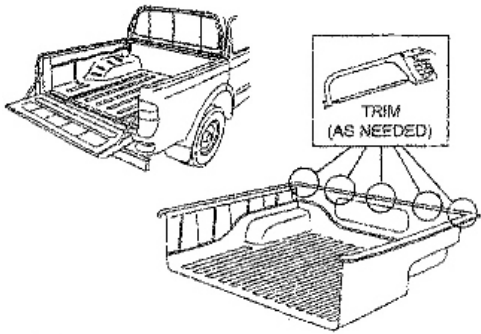
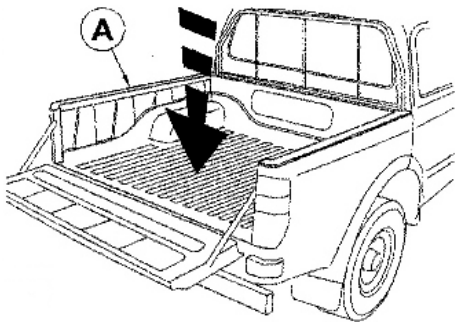
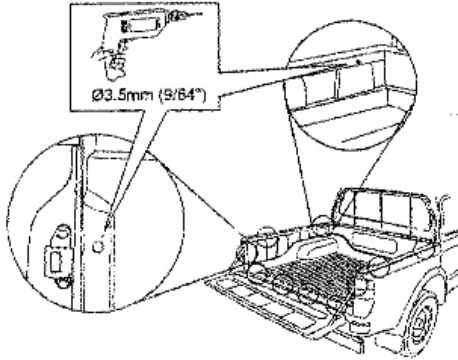
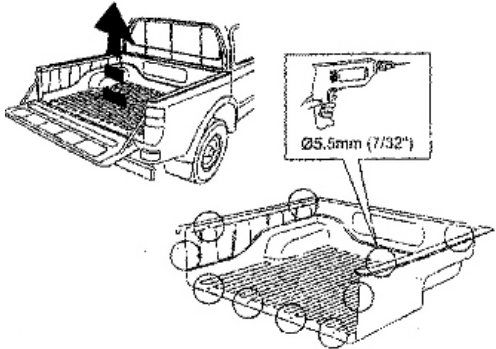
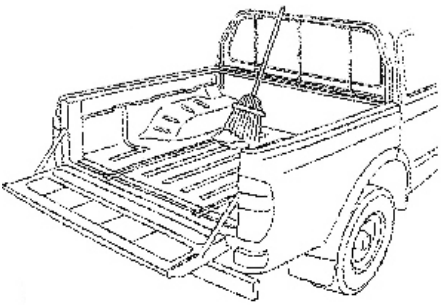
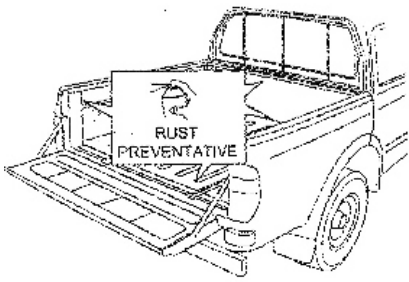
Szerelési útmutató:

7. Tegye a platóbélést a platóba és rögzítse a csavarokkal.

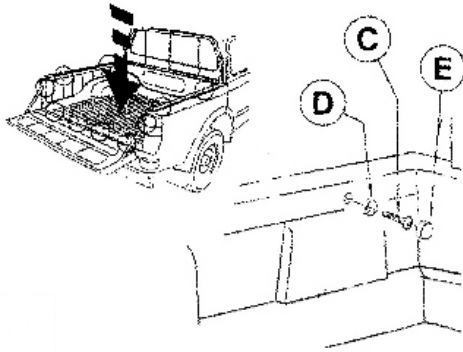

8. Vegye ki a platóajtóból a csavarokat.

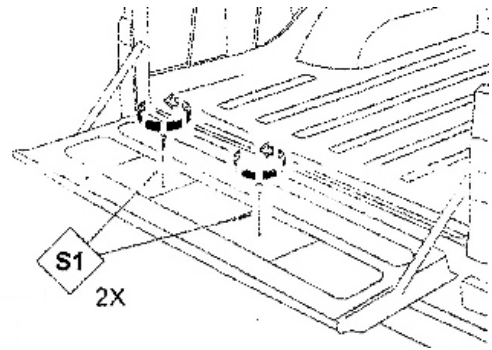

9. Tisztítsa meg a felületét.

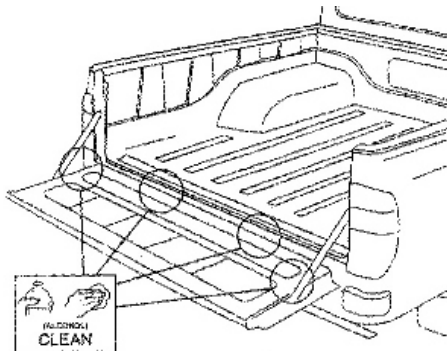

10. Fújja be korrózió gátló spray-vel.

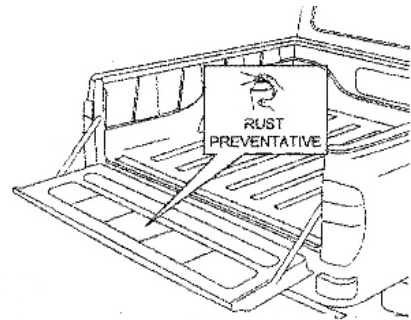

11. Helyezze fel a ragasztószalagot.

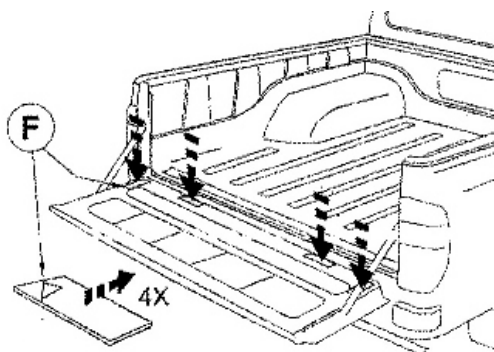

12. Tegye rá a hátfalat, és húzza meg a csavarokat.

